

## Technical Information Sheet

Copyright 2009

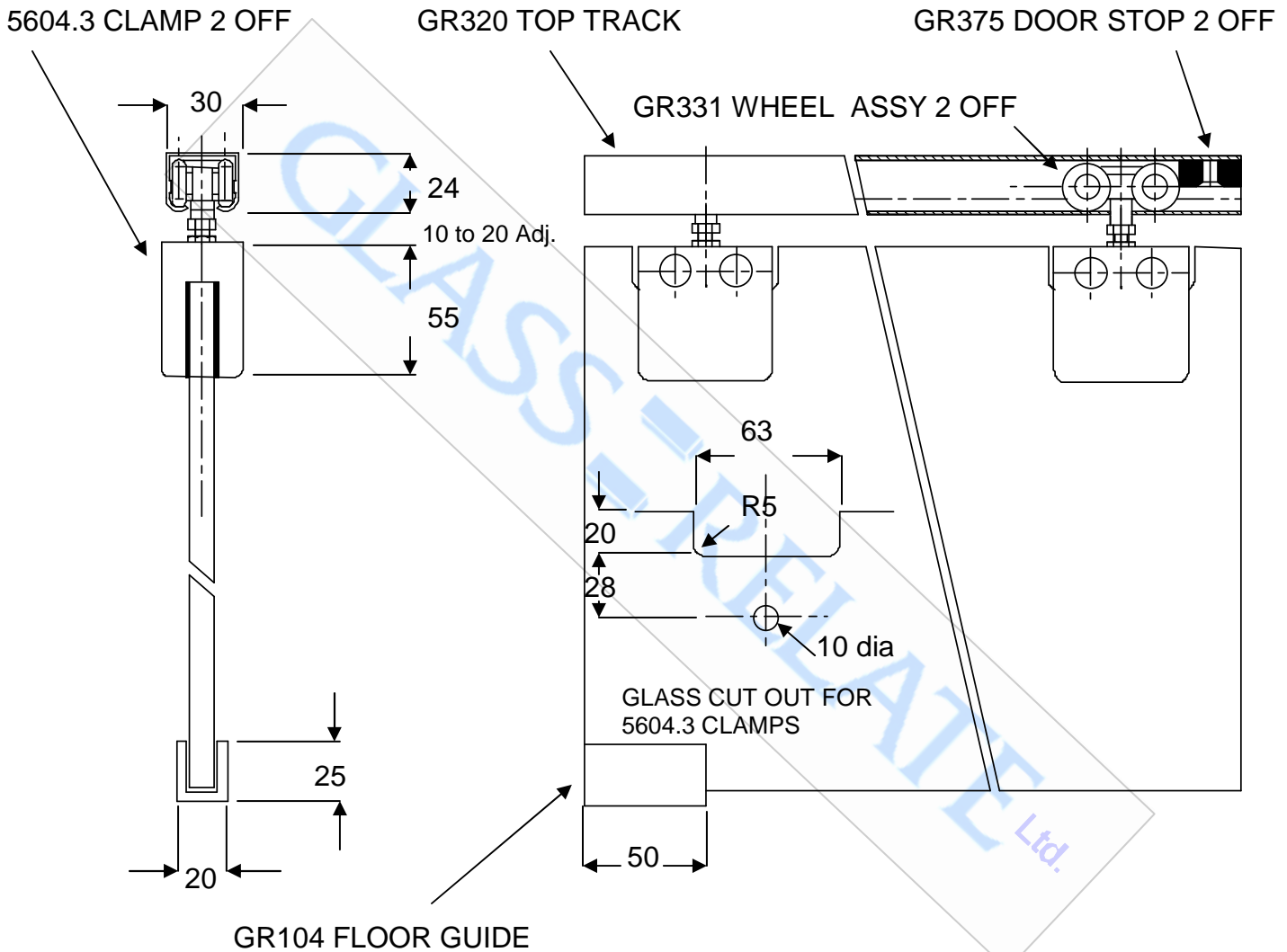

### MEDIUM DUTY SLIDING DOOR SET UP USING GR5604.3 CLAMPS

**MAX LOAD PER DOOR = 50 KG**